

PERMA-TITE QUICKLOCK RADIUS COPING

EXISTING SLOPE WITH NAILER VERSION

IMPORTANT!!! MUST INDICATE PROPER RADIUS CONDITION BY CIRCLING APPROPRIATE OUTSIDE FACE

PROVIDING A RADIUS
THE RADIUS MAY BE PROVIDED
IN ONE OF TWO METHODS:

1.) THE ACTUAL KNOWN RADIUS IS

_____ ' FEET _____ " INCHES

MINIMUM
OF 3'-0"

OR

2.) FIELD CONDITION MEASUREMENTS

NOTE: REFER TO ATTACHED WORKSHEET
FOR FURTHER INFORMATION

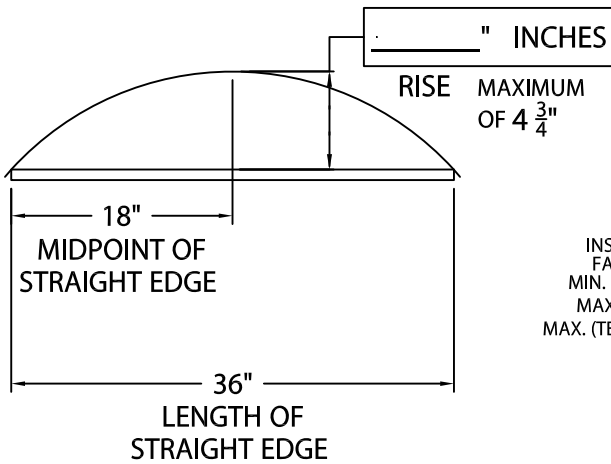

NOTE: CHECK MEASUREMENTS ALONG ENTIRE RADIUS.

DETAIL A

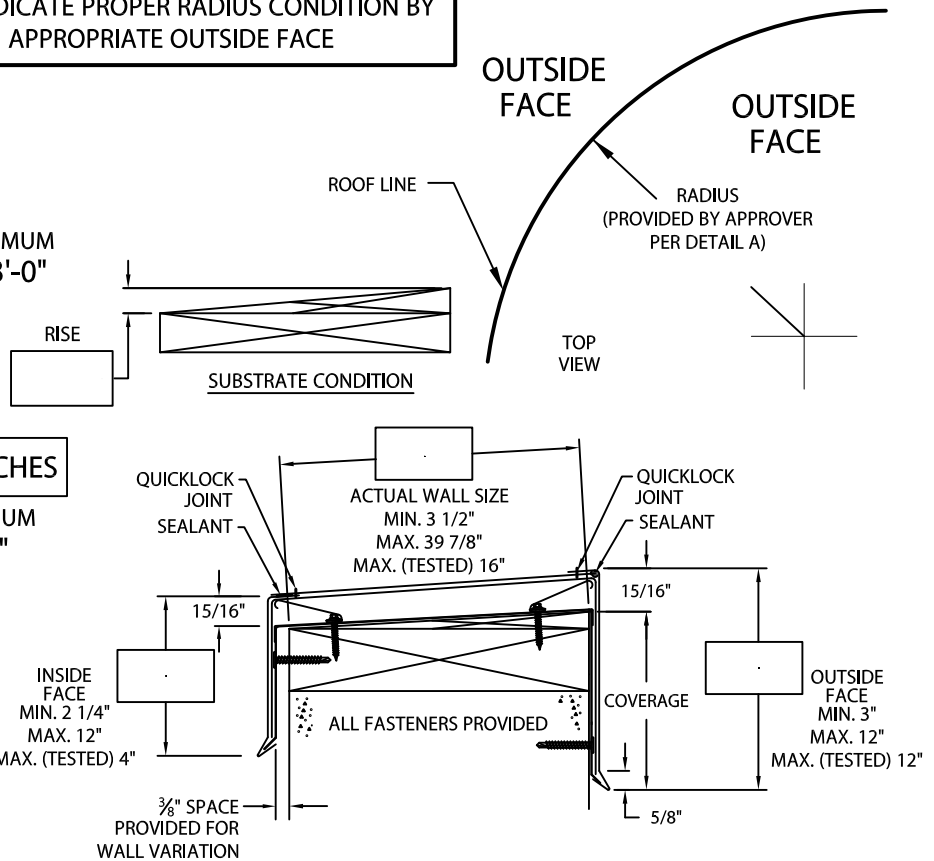

NOTES: -- Concealed splice plates are provided with factory applied dual non-curing sealant strips.

-- Fabrication of radius is furnished utilizing a non-penetrating quicklock joint, then factory sealed watertight.

Fabrication will proceed only after receipt of signed print approval.

Print Approval:

Architect and/or contractor shall verify all dimensions, sizes and quantities. All products to be installed in strict accordance with Metal-Era's printed instructions.

Approved by: _____

Date: _____

MATERIAL:

- ___ 24 Ga. Steel
- ___ .040" Aluminum
- ___ .050" Aluminum
- ___ .063" Aluminum
- ___ Other _____

Color: _____

Finish: _____

QUANTITIES:

_____ Lineal Feet 4'-0" Lengths

PROJECT:

ARCHITECT:

ROOFING CONTRACTOR:

REPRESENTATIVE/DISTRIBUTOR:

Corporate Offices, Manufacturing
1600 Airport Road; Waukesha, WI 53188
Phone: 800-558-2162
Fax: 800-373-9156
www.metalera.com



DATE: 12/13/21

DRN BY: MLM

CKD BY: MM

SHT.# ____ OF ____

DWG# 11011-37518

A