

PERMA-TITE COPING

FLAT

* NOTES

- Oil canning can occur on larger face heights and wall widths; recommend 22 Ga., .050" or .063" Aluminum for face height over 8" or wall width over 12".

- 24 Ga. and .040" Aluminum covers available for wall sizes 3.5" to 24" ONLY

- Unless otherwise noted, fabrication of miters and accessories are furnished standard utilizing a non-penetrating quicklock joint, then factory sealed watertight

- Welded accessories require a minimum material thickness of .050" Aluminum

- For non-90 miters, see separate print approval

- Product should be installed per provided installation instructions

- ANSI/SPRI/FM 4435/ES-1 test pressures up to 226 psf (Horizontal) and 391 psf (Vertical)

8" WIDE CONCEALED SPLICE PLATE WITH FACTORY APPLIED DUAL NON-CURING SEALANT STRIPS AT EACH JOINT

COPING COVER (12'-0" LENGTHS)

12" WIDE 20 GALV. ANCHOR CLIPS SPACING DETERMINED BY MANUFACTURER

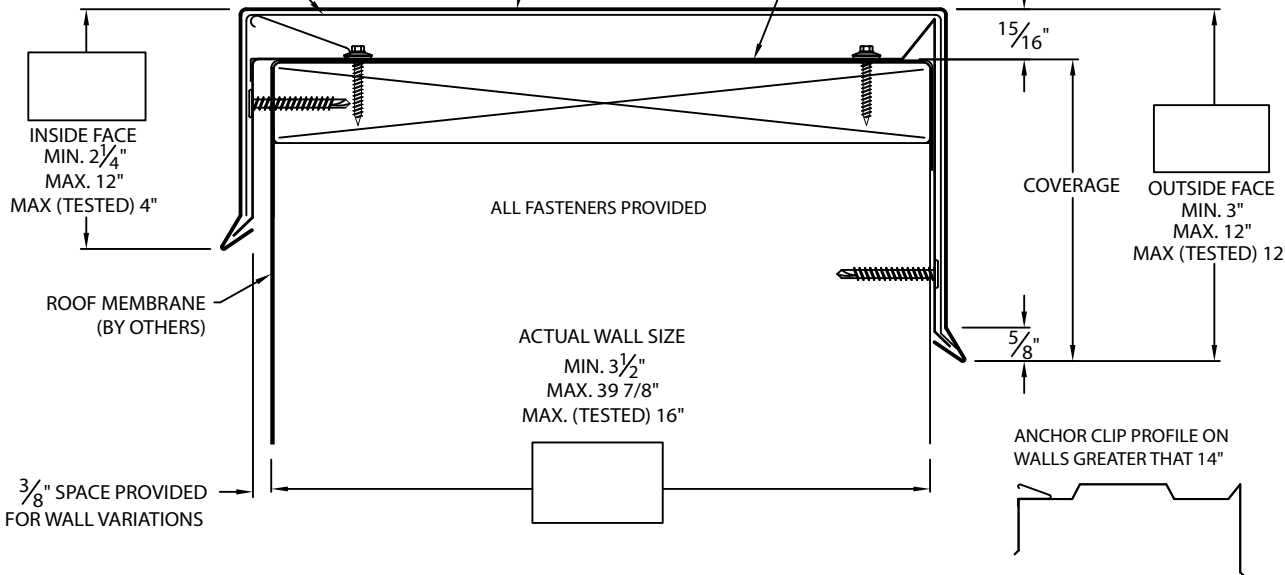

APPROVALS*

ANSI/SPRI/FM 4435/ES-1
Test Pressures listed in notes



MIAMI-DADE COUNTY
APPROVED

MATERIAL*

- 24 Ga. Galv. Steel
- 22 Ga. Galv. Steel
- .040" Aluminum
- .050" Aluminum
- .063" Aluminum
- OTHER: _____

Color: _____

Finish: _____

Substrate: (For Top Fasteners)

if substrate is not given, wood fasteners will be provided.

- Wood
- Masonry
- Metal

QUANTITIES

_____ Lineal Feet (12'-0" Lengths)

_____ Outside Miter (90°)

_____ Inside Miter (90°)

_____ Right Endcaps

_____ Left Endcaps

Accessory Type* : Quicklock (Default) Welded (Surcharge)

_____ Right Endwall Flashing (Coping Version)

_____ Left Endwall Flashing (Coping Version)

_____ Right Endwall Flashing (Splice Plate Version)

_____ Left Endwall Flashing (Splice Plate Version)

Project Name: _____

Architect: _____

Roofing Contractor: _____

Project Type:

By selecting this box you have verified and confirmed that dimensions, sizes, and quantities are correct. All products will be installed in strict accordance with printed instructions.

Date: _____

Metal-Era LLC
1600 Airport Rd.
Waukesha, WI 53188
Phone: 800-558-2162
www.metalera.com

SHT# 1 of 2

DATE: 05/20/22

DRN BY: JJC

CKD BY: MM

DWG #: 11011-19146

REV: G

PERMA-TITE COPING

STANDARD ACCESSORIES

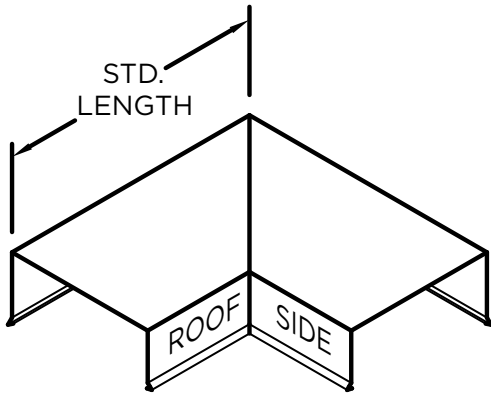

OUTSIDE MITER

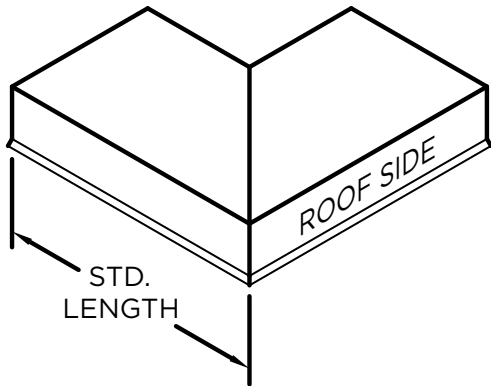

INSIDE MITER

MITER STANDARD LEG LENGTH:
WALL SIZE + $9 \frac{5}{8}$ " = LENGTH

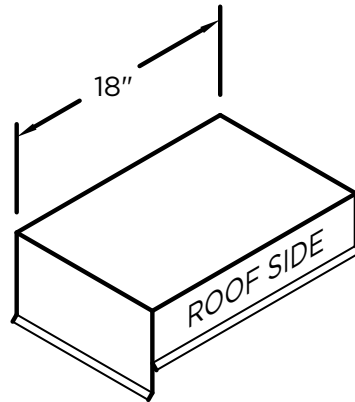

ENDCAP
(LEFT HAND SHOWN)

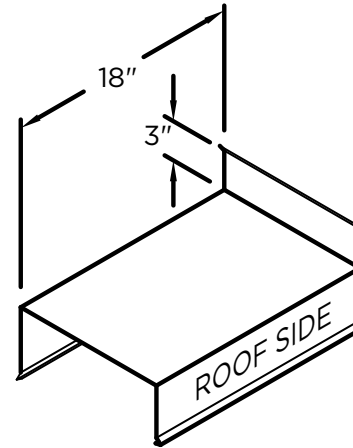

ENDWALL FLASHING
COPING VERSION
(RIGHT HAND SHOWN)

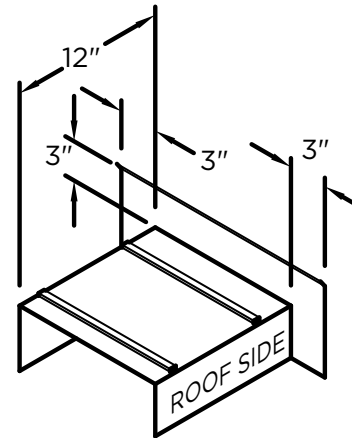

ENDWALL FLASHING
SPLICE PLATE VERSION
(RIGHT HAND SHOWN)
(AVAILABLE ONLY IN
.040" WELDED, PAINTED
TO MATCH COPING)

NOTES

Additional accessories are available including:

- Transition Miters
- Straight Transition Miters
- "T" Miters
- "Z" Miters
- Step-up Miters
- Peak / Valley Miters
- Pilaster Caps
- Radius Coping
- Arched Coping

For additional accessory requirements, attach sketches or call manufacturer for assistance.

SHT# 2 of 2

DATE: 05/20/22

DRN BY: JJC

CKD BY: MM

DWG #: 11011-19146

REV: G

Metal-Era LLC
1600 Airport Rd.
Waukesha, WI 53188
Phone: 800-558-2162-9156
www.metalera.com