



PERMA-TITE RADIUS COPING

EXISTING SLOPE VERSION - 4'-0" O.C.

INSTALLATION INSTRUCTIONS

NOTE: Position roof membrane on top of the wall covering the treated wood nailer(s) or substrate completely. Allow 1/2" minimum excess membrane beyond nailer where applicable. NRCA Requirement.

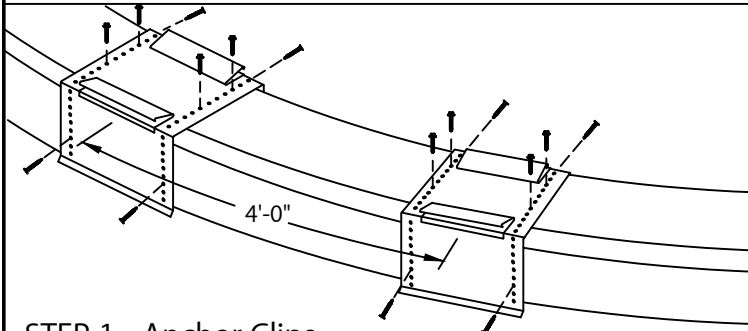

STEP 1 - Anchor Clips

Locate and fasten anchor clips at 4'-0" O.C. with provided fasteners for substrate (see detail A).

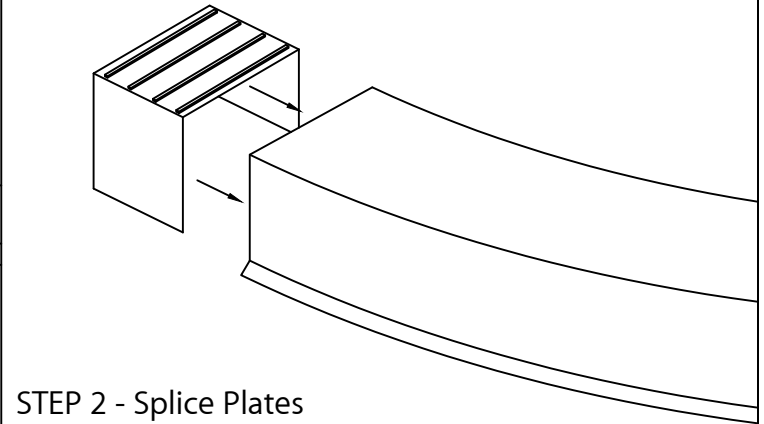

STEP 2 - Splice Plates

Remove release paper from left two sealant strips. Insert splice plate into the right end of radius section.

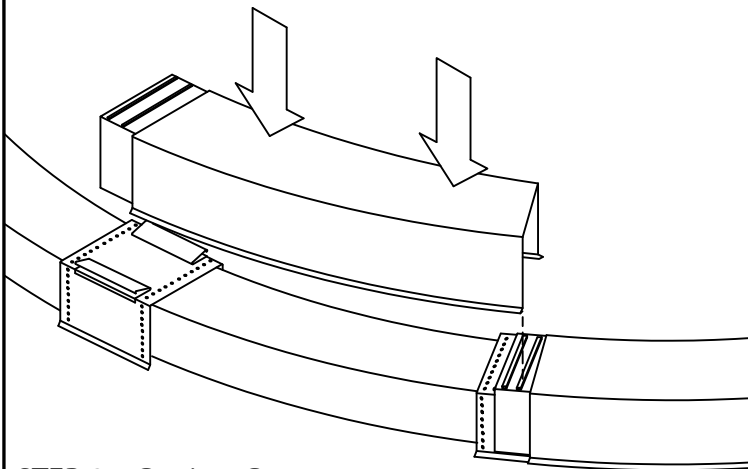

STEP 3 - Coping Cover

Remove release paper from right two factory applied sealant strips on the splice plate in the coping section. Install 4'-0" radius coping sections from left to right. Place coping into position and press downward until snap-lock occurs.

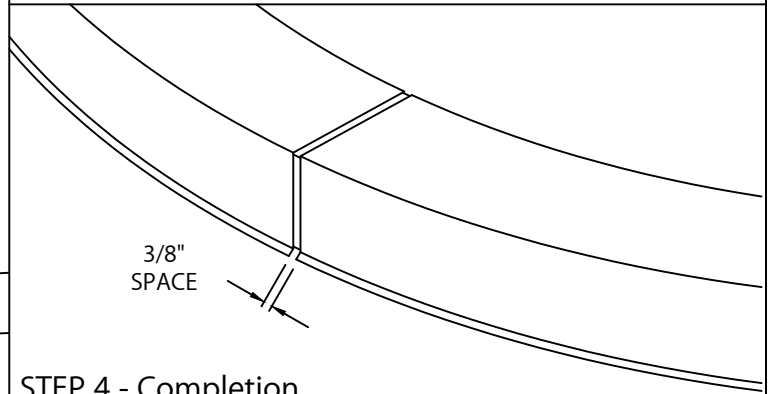

STEP 4 - Completion

Continue installing coping with a 3/8" space at splice joints to allow for thermal expansion. Field cut where necessary using a fine tooth hacksaw or snips.

NOTE: REMOVE PROTECTIVE FILM IMMEDIATELY.

ANCHOR CLIP FASTENING-DETAIL A

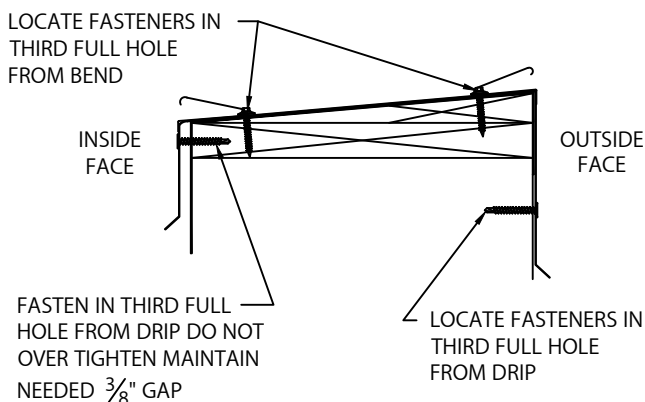

TYPICAL COPING INSTALLATION

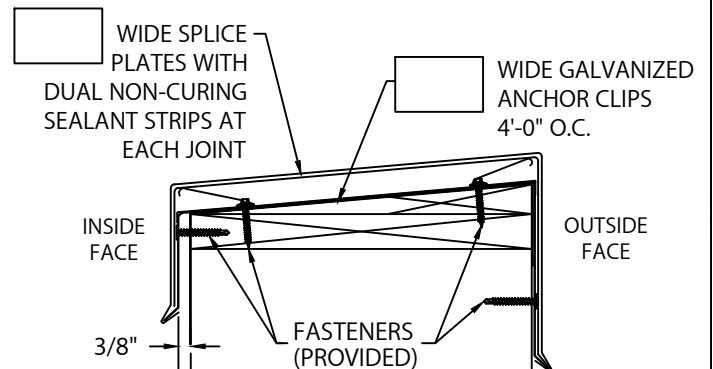

Phone: 800-558-2162
Fax: 800-373-9156
www.metalera.com

DATE: 12/02/21
DRN BY: MLM
CKD BY: MM

SHT.# ___ OF ___
DWG# 11111-37465

A