

# CREATIVE DESIGN REVEAL COPING

3'-0" O.C.

## INSTALLATION INSTRUCTIONS

**IMPORTANT:** Prior to installation, read instructions carefully.

**NOTE:** Position roof membrane on top of the wall covering the treated wood nailer(s) or substrate completely. Allow 1/2" minimum excess membrane beyond nailer where applicable. NRCA requirement. Membrane not shown for clarity.

**CAUTION:** INSTALL MITERS FIRST!

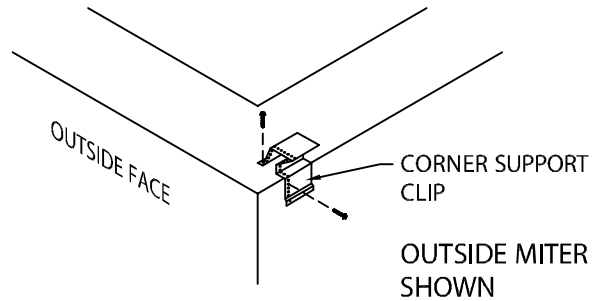

### STEP 1 - CORNER SUPPORT CLIPS

LOCATE AND FASTEN ONE 5 1/2" WIDE GALVANIZED CORNER SUPPORT CLIP TO THE WALL AS SHOWN.

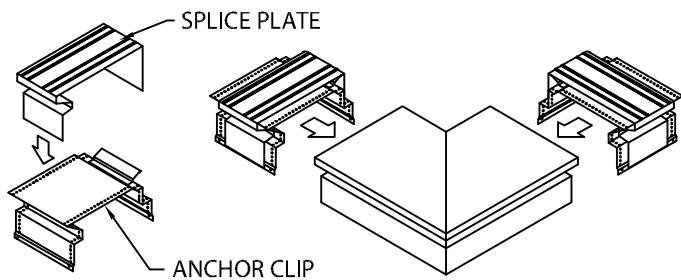

### STEP 2 - MITER SPLICE PLATES & ANCHOR CLIPS

POSITION THE SPLICE PLATE IN THE CENTER OF THE ANCHOR CLIP. INSTALL THE SPLICE PLATE AND ANCHOR CLIP ASSEMBLY INTO EACH END OF THE CORNER AS SHOWN

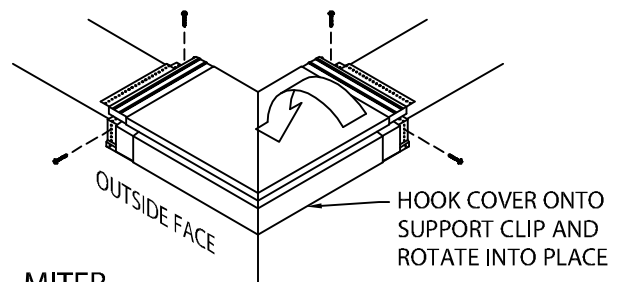

### STEP 3 - MITER

HOOK MITER ONTO CORNER CLIP AND ROTATE INTO PLACE. SECURE AT THE EXPOSED EDGE OF THE ANCHOR CLIPS AS PER DETAIL A.

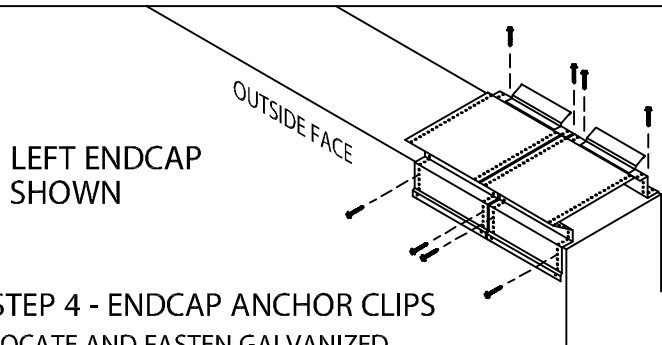

### STEP 4 - ENDCAP ANCHOR CLIPS

LOCATE AND FASTEN GALVANIZED ANCHOR CLIPS TO WALL WITH PROVIDED FASTENERS FOR SUBSTRATE (SEE DETAIL A).

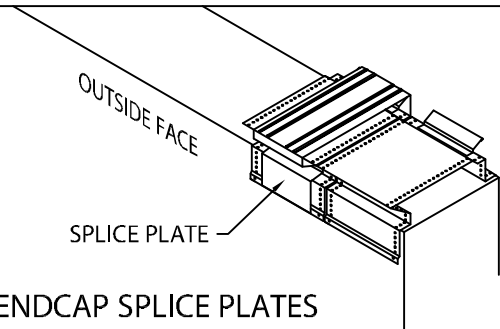

### STEP 5 - ENDCAP SPLICE PLATES

REMOVE RELEASE PAPER FROM TOP OF FACTORY APPLIED SEALANT STRIPS. PLACE SPLICE PLATE ONTO SECOND ANCHOR CLIP AS SHOWN.

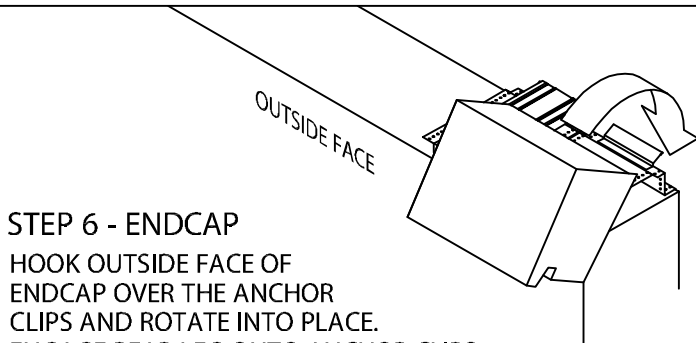

### STEP 6 - ENDCAP

HOOK OUTSIDE FACE OF ENDCAP OVER THE ANCHOR CLIPS AND ROTATE INTO PLACE. ENGAGE REAR LEG ONTO ANCHOR CLIPS BY PRESSING DOWNWARD UNTIL SNAP LOCK OCCURS.

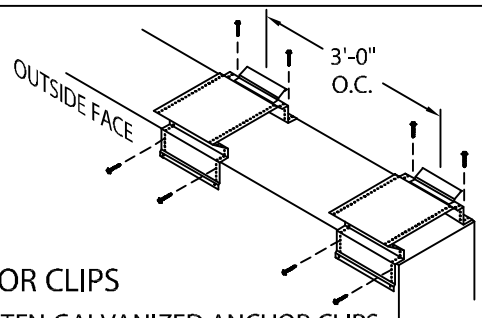

### STEP 7 - ANCHOR CLIPS

LOCATE AND FASTEN GALVANIZED ANCHOR CLIPS TO WALL AT 3'-0" CENTERS WITH PROVIDED FASTENERS FOR SUBSTRATE (SEE DETAIL A).



Phone: 800-558-2162  
 Fax: 800-373-9156  
 www.metalera.com

DATE: 03/24/15  
 DRN BY: JJC  
 CKD BY: SAK

SHT.# 1 OF 2  
 DWG# 11111-17435

C

# CREATIVE DESIGN REVEAL COPING

3'-0" O.C.

## INSTALLATION INSTRUCTIONS

### INSTALLATION NOTES:

1) Installing contractor shall check as-built conditions, including nailer attachment, and verify the manufacturer's coping details for accuracy to fit the wall assembly prior to fabrication.

2) Fasteners must be corrosion resistant and rated for a minimum 250# pullout force for the substrate that is being used.

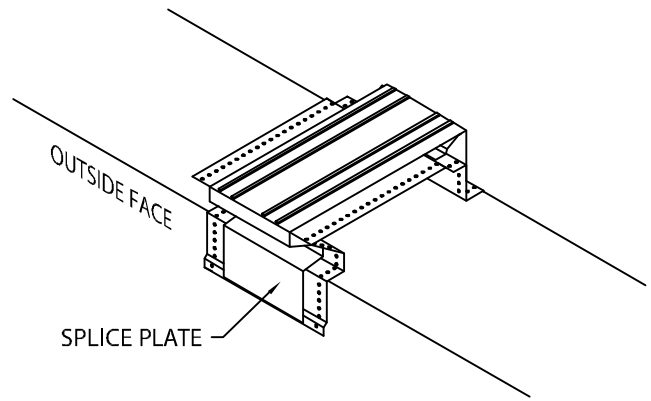
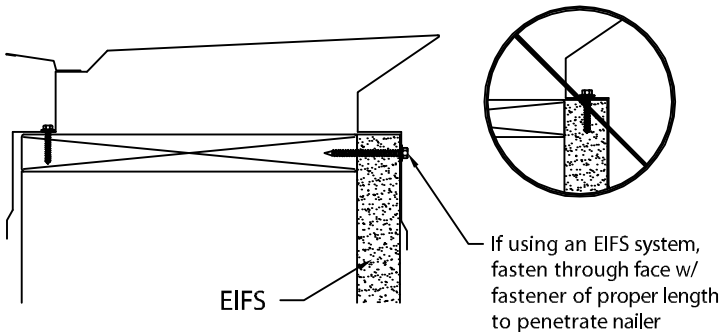

### STEP 8 - SPLICE PLATES

PLACE SPLICE PLATE ONTO ANCHOR CLIPS AT SPLICE JOINTS, 12'-0" O.C.  
NOTE: REMOVE RELEASE PAPER FROM SEALANT STRIPS.

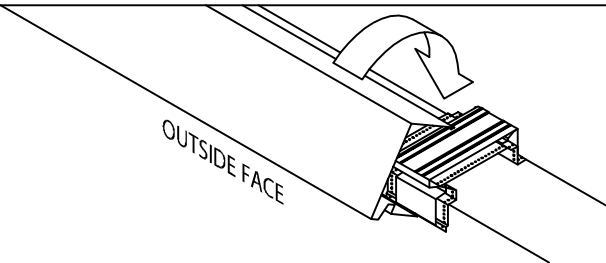

### STEP 9 - COPING

HOOK OUTSIDE FACE OF COPING OVER THE ANCHOR CLIPS AND ROTATE INTO PLACE. ENGAGE REAR LEG ONTO ANCHOR CLIPS BY PRESSING DOWNWARD UNTIL SNAP LOCK OCCURS.

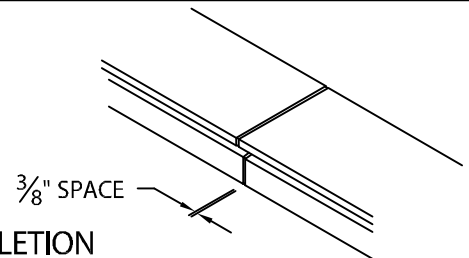

### STEP 10 - COMPLETION

CONTINUE INSTALLING COPING WITH A 3/8" SPACE AT SPLICE JOINTS TO ALLOW FOR THERMAL EXPANSION. FIELD CUT WHERE NECESSARY USING FINE TOOTH HACKSAW OR SNIPS.  
NOTE: REMOVE PROTECTIVE FILM IMMEDIATELY.

## TYPICAL COPING INSTALLATION

### DETAIL A

